

BRECKWELL

Hearth Products

LUXURY SERIES P2000

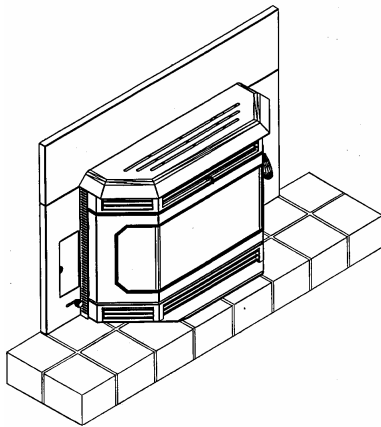

P2000I

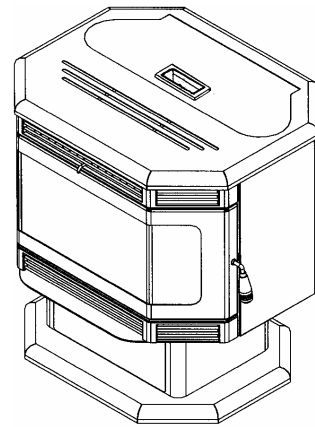

P2000FS

OWNER'S MANUAL

- **Warning:** If your appliance is not properly installed a house fire may result. For your safety, follow the installation directions. Contact local building or fire officials about restrictions and installation inspection requirements in your area.
- **PLEASE** read this entire manual before installation and use of this pellet fuel-burning room heater. Failure to follow these instructions could result in property damage, bodily injury, or even death.
- Save these instructions

PROFESSIONAL INSTALLATION IS HIGHLY RECOMMENDED

Manufactured by
National Steelcrafters of Oregon, Inc.
DBA Breckwell Hearth Products
Eugene, Oregon
Grand Prairie, Texas

©BRECKWELL HEARTH PRODUCTS
C-L-802 1/05



FAILURE TO CLEAN AND MAINTAIN THIS UNIT AS INDICATED CAN RESULT IN POOR PERFORMANCE AND SAFETY HAZARDS. NEVER CLEAN WHEN HOT.

NOTE: Inspect burn pot periodically to see that holes have not become plugged, if so, clean thoroughly.

ASH REMOVAL

Ashes should be placed in a metal container with a tight-fitting lid. The closed container or ashes should be placed on a noncombustible surface or on the ground, well away from all combustible materials pending final disposal. If ashes are disposed of by soil burial or otherwise locally dispersed, they should be retained in the closed container until all cinders have thoroughly cooled.

ASH DISPOSAL – FREESTANDING MODELS

The P2000 Freestanding has an ash bin located below the firebox. To remove ashes:

- a. Make sure fire is out and firebox is cool.
- b. With the door closed clean heat exchanger tubes. (See “**CLEANING**” and Figure 22).
- c. Open door and remove the optional imitation log set, if in use. Remove the burnpots inner section by grasping it and pulling straight up (see Figure 23).
- d. Empty ashes from inner section into the pedestal ash bin through the opening in the bottom of the firebox. Scrape inner section with cleaning tool. Make sure holes are not plugged.
- e. Scrape ash in firebox into the pedestal ash bin through the opening in the bottom of the firebox or vacuum to remove ashes.
WARNING: Make sure ashes are cool to the touch before using a vacuum. See “**VACUUM USE**”.
- f. Periodically remove and empty ash bin (see Figure 24) by unscrewing the two knobs on the front of the pedestal below the ash lip. Dispose of ashes properly. (See “**ASH REMOVAL**” above)
- g. Replace ash bin, making sure to tighten the knobs and maintaining a good seal.
- h. Replace inner section into burnpot; make sure it is level and pushed all the way back down and that the igniter hole is to the rear when it is reinstalled (see Figure 23).
- i. Make the burnpot is level and pushed all the way back in when it is reinstalled. If the collar on the burnpot attached to the fresh air tube is not pushed back to meet the firebox wall, the Hot Rod will not work properly.

ASH DISPOSAL - INSERT

Remove ashes periodically as they fill the firebox. To remove ashes:

- a. Make sure fire is out and firebox is cool.
- b. With the door closed clean heat exchanger tubes. (See “**CLEANING**” and Figure 22).
- d. Open door and remove the optional imitation log set, if in use. Remove the burnpots inner section by grasping it and pulling straight up (see Figure 23).
- e. Empty ashes from the inner section and scrape with cleaning tool; make sure holes are not plugged.
- f. Use small shovel or vacuum to remove ashes.
WARNING: Make sure ashes are cool to the touch before using a vacuum. See “**VACUUM USE**”.
- a. Dispose of ashes properly. (See “**ASH REMOVAL**” above)
- j. Replace inner section into burnpot; make sure it is level and pushed all the way back down and that the igniter hole is to the rear when it is reinstalled (see Figure 23).
- g. Make the burnpot is level and pushed all the way back in when it is reinstalled. If the collar on the burnpot attached to the fresh air tube is not pushed back to meet the firebox wall, the Hot Rod will not work properly.

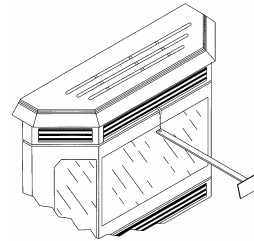
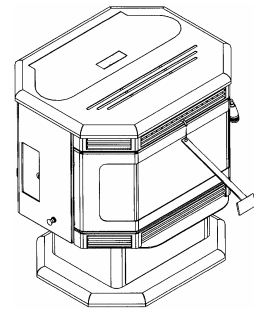

FIGURE 22

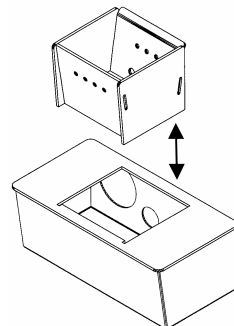
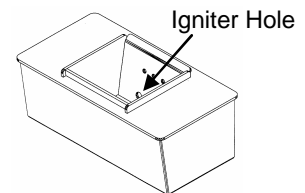

FIGURE 23

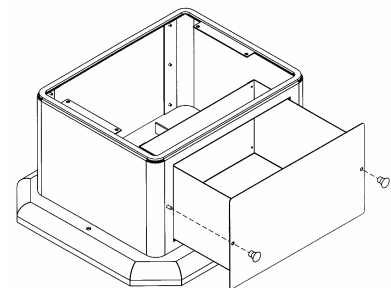

FIGURE 24

VACUUM USE

If a vacuum is used to clean your unit, we suggest using a vacuum designed for ashes.

(We recommend LoveLess Ash Vac, 1-800-568-3949 Ext. #27)

Some regular vacuums and shop vacs leak ash into the room. Your vacuum or shop vac may have a special filter or bag available to eliminate this leakage.

CLEANING

- Heat Exchange Tubes** – Your Breckwell stove is designed with a built-in heat exchange tube cleaner. This should be used every two or three days to remove accumulated ash on the tubes, which reduces the efficiency of your unit. Insert the handle end (with hole) of the cleaning tool onto the cleaning rod (refer to figure 22). The cleaner rod is located in the grill above the stove door. Move the cleaner rod back and forth several times to clean the heat exchanger tubes. When finished be sure to leave tube cleaner at the rear of the stove.
- Interior Chambers** – Three ash doors and an upper baffle in the firebox in the P2000 can be removed for periodic cleaning (Figure 25). These doors allow access to the chamber surrounding the firebox.

NOTE: When removing the upper baffle do not remove the screw; just loosen it enough to allow the baffle to be removed.

Periodically, you must vacuum ashes from these chambers. In some cases you will need to remove creosote, which can accumulate rapidly under certain conditions. A small wire brush can be used. It is important to remove this creosote because it is highly combustible. **INSPECT BEHIND THESE CLEANING PLATES AT LEAST ONCE PER TON OF PELLETS BURNED UNTIL YOU ARE FAMILIAR WITH HOW ASHES AND CREOSOTE ACCUMULATE WITH YOUR OPERATING PRACTICES.** Use the small wire brush to also clean the inside of the chamber walls, above the access doors.

BLOWERS

DANGER: RISK OF ELECTRIC SHOCK. DISCONNECT POWER BEFORE SERVICING UNIT.

- Cleaning** – Over a period of time, ashes or dust may collect on the blades of both the combustion blower and convection blower. Periodically the blowers should be cleaned as the ash and dust can impede performance. Creosote can also accumulate on the blades in the combustion blower. This needs to be brushed clean. The convection blower is accessed by opening the stove's left side panel. The combustion blower can be accessed by opening the stove's right side panel. The convection blower is on the left (facing stove), and the combustion blower is on the right.

NOTE: When cleaning, be careful not to dislodge balancing clip on convection blower or to bend fan blades. Some stove owners lightly spray an anti-creosote chemical on the fire to help reduce creosote formation within the stove.

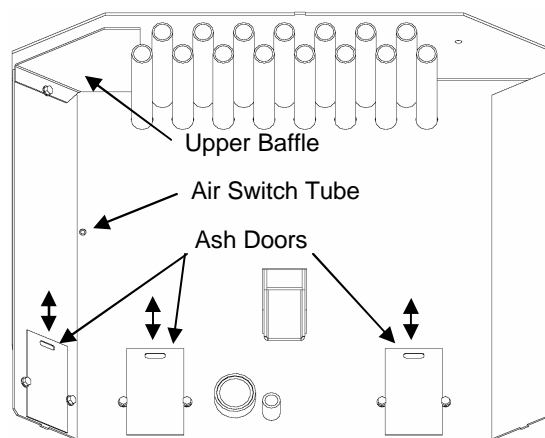
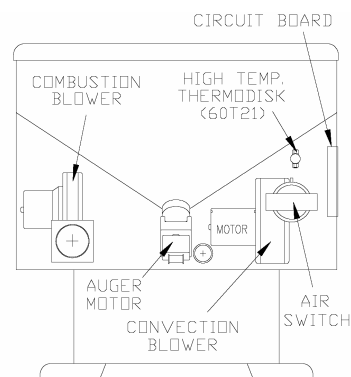
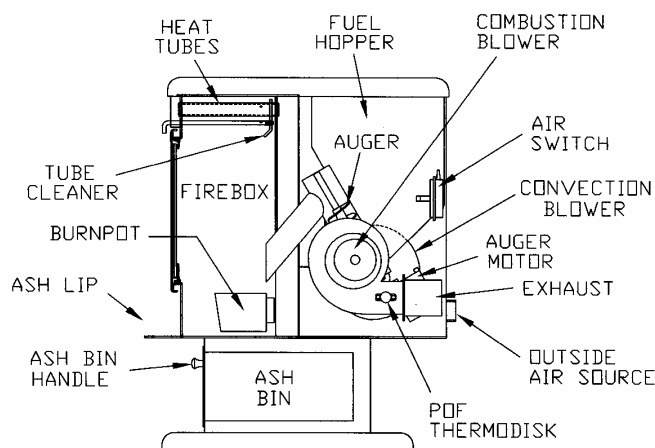

FIGURE 25



REAR VIEW – P2000FS

FIGURE 26a



SIDE CUTAWAY – P2000FS

FIGURE 26b

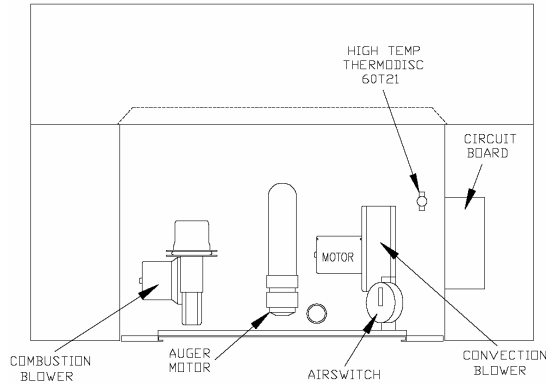

FIGURE 27a

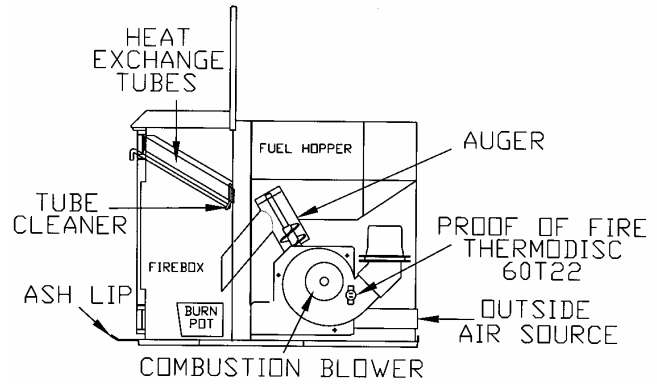

FIGURE 27b

CHIMNEY CLEANING

- a. **Creosote Formation** – When any wood is burned slowly, it produces tar and other organic vapors, which combine with expelled moisture to form creosote. The creosote vapors condense in the relatively cool chimney flue or a newly started fire or from a slow-burning fire. As a result, creosote residue accumulates on the flue lining. When ignited, this creosote makes an extremely hot fire, which may damage the chimney or even destroy the house. Despite their high efficiency, pellet stoves can accumulate creosote under certain conditions.
- b. **Fly Ash** – This accumulates in the horizontal portion of an exhaust run. Though noncombustible, it may impede the normal exhaust flow. It should therefore be periodically removed.
- c. **Inspection and Removal** – The chimney connector and chimney should be inspected annually or per ton to determine if a creosote or fly ash build-up has occurred. If creosote has accumulated, it should be removed to reduce the risk of a chimney fire. Inspect the system at the stove connection and at the chimney top. Cooler surfaces tend to build creosote deposits quicker, so it is important to check the chimney from the top as well as from the bottom.

The creosote should be removed with a brush specifically designed for the type of chimney in use. A qualified chimney sweep can perform this service. It is also recommended that before each heating season the entire system be professionally inspected, cleaned and, if necessary, repaired.

To clean the chimney, detach the vent at the combustion blower transition where it is attached to the blower. (See figure 28 for the P2000 Insert)

RECOMMENDED MAINTENANCE SCHEDULE

Use this as a guide under average-use conditions.

	Daily	Weekly	Annually or per Ton
Burn Pot	Stirred	Emptied	
Glass	Wiped	Cleaned	
Combustion Chamber		Brushed	
Ashes			Emptied
Interior Chambers			Vacuumed
Heat Exchange Tubes		Two passes	
Combustion Blower Blades			Vacuumed / Brushed
Convection Blower Impeller			Vacuumed / Brushed
Vent System			Cleaned
Gaskets			Inspected
Hopper (end of season)			Emptied and vacuumed

Gasket around door and door glass should be inspected and repaired or replaced when necessary (see “**REPLACEMENT PARTS**”).

REMOVAL AND REPLACEMENT OF BROKEN DOOR GLASS

While wearing leather gloves (or any other gloves suitable for handling broken glass), carefully remove any loose pieces of glass from the doorframe. Dispose of all broken glass properly. Return the damaged door to your Breckwell Dealer for repair or replacement. Neither the appliance owner nor any other unauthorized person(s) should replace the door glass. An authorized Breckwell dealer must perform all repairs involving door glass.